

Silent Messenger

Double-Sided Message Board

The “Silent Messenger” Double-Sided Message Board is ideal for directing traffic from two different directions.

Model MB-122-3048 has two sign panels on a lift and rotate mast. The sign panels can be angled from parallel to 45 degrees. The sign is powered by a combination of solar panels and batteries for reliable performance.

OPTIONAL REMOTE COMMUNICATIONS

When choosing this option, your Double-Sided Message Board will come with a GPS receiver, a cellular transceiver, and **FREE lifetime cellular service***.

Use with SolarTech’s Command Center software to track your equipment.

Manage your fleet from your laptop, PC, or smartphone... without leaving your desk!

Access units from a map or list. Control units individually or broadcast to a group.

You can build a message library, share messages between boards, schedule messages, and more.

Get automatic email notifications when a message changes, if the battery voltage is low, if a panel or module fails, or the unit moves.

PRODUCT GUIDE



EASY-TO-USE CONTROLLER

- ▶ Password Protection
- ▶ Intuitive Icons for Ease of Use
- ▶ Scheduling Capability
- ▶ Fully Networkable
- ▶ NTCIP version 3 Compatible

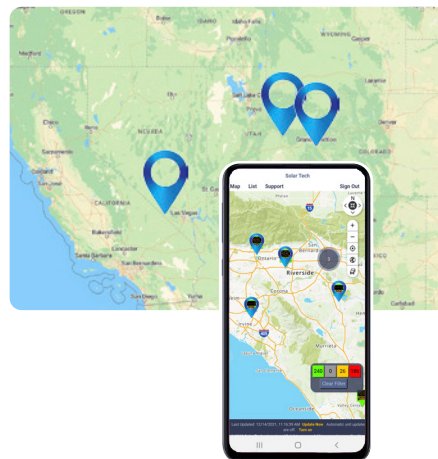

Keep tabs on your whole fleet. No more misplaced equipment... fewer problems... less downtime!

Learn more at www.solartech.com

Silent Messenger

Double-Sided Message Board

Display Panel	MB-122-3048 Lift & Rotate
Panel Size	92" x 54"
Panel Construction.....	All aluminum, modular construction
Matrix Size.....	27 x 48 pixels
Pixel Pitch	1.77" (45 mm)
Characters per Line.....	Up to twelve (12)
Character Height.....	12" to 38" (30.5 cm to 97 cm)
Graphics Capability.....	Full matrix with full animation
Display Technology	LED (amber, 592 nm)
Display Brightness	>10,000 cd/m2 (candela per sq. meter)
Display Life Expectancy	10 years
Lifting Mechanism.....	2,000 lb. capacity electro-hydraulic
Sign Panel Rotation.....	> 360 degrees (mast rotation); Auxiliary sign panel rotates independently of main sign panel up to 45° either side.

Trailer

Length Overall	180" (457 cm)
Width Overall.....	92" (234 cm)
Height Traveling.....	103" (262 cm)
Height Operating.....	164" (417 cm)
Ground Clearance	13" (33 cm)
Weight.....	3,100 lbs (max) (1,407 kg) approx.
Coupler (Class III).....	2" (50 mm) ball or 3" (76 mm) pintle ring
Brakes.....	7,500 lb. hydraulic surge
Axle/Suspension.....	Torq flex, independent

Mega-Tech Control Console

Console Circuitry	Ultra-low-power solid state
Console Touchscreen.....	Weather-resistant, backlit, full color GUI, intuitive icon-driven, multi-lingual
Programming Software.....	Proprietary, field upgradable (for units not connected to Command Center)
Message Capacity.....	Pre-programmed and user programmed - greater than 250 each
Time/Date Control	Real time clock/calendar (365 day)
Message Display Time	User-selectable (0.1 to 99 seconds)
Display Update Time	Instantaneous
Non-Volatile Memory	16 GB Micro SD card
Password Protection.....	User-selectable, multi-level
Operator Interface.....	Easy-to-use icons - no instruction manual needed

Energy Source

Operating Voltage.....	12 volts DC (nominal)
Battery Type	6 volt heavy duty, deep cycle (GC-2)
Number of Batteries.....	Twelve (12) lead acid (flooded)
Battery Bank Capacity	1,560 amp hours
Battery Status Indicator.....	Displays battery voltage, charging activity, and low battery condition
Solar Array Construction.....	Top mounted solar panels in aluminum frame
Solar Array Power Output	330 watts (nominal)
Solar Charge Controller	Automatic, temperature compensated

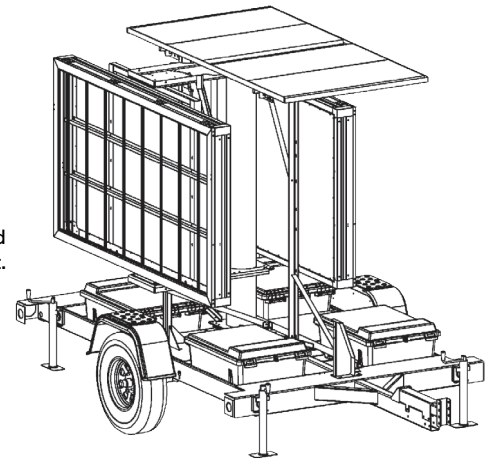

Shown folded for transport.

OPTIONS AND UPGRADES

Remote Communications

Includes a GPS receiver, cellular transceiver, and FREE lifetime cellular service. Remotely access and track your Double-Sided Message Board.

**With this option, cellular service is provided free of charge, and is limited to carrier supported generational wireless technology.*

Second Controller

» Enables independent local and remote control of each sign.

Solar Array Upgrades

» 440 watt » 550 watt » 660 watt

Battery Upgrades

» Twelve (12) maintenance-free (Gel-Cell or AGM) - 1,560 amp hour capacity

Security Option

» Anti-theft steel battery frame bolted to trailer
» Vandal-proof battery box with reinforced steel cage

Battery Charger Options

» 45 amp, 120 volt AC
» 55 amp, 120 volt AC
» 90 amp, 120 volt AC

Brakes

» Electric Brakes

Radar Options - Both Trailers

Directional doppler K-Band, user-configured KPH or MPH
Data collection and statistical analysis package included.

Panel Sizes

» Contact SolarTech for additional panel sizes.

Learn more at www.solartechology.com